

# Updated and practical Periodic Table of the Elements designed for secondary and higher education

	GROUP 1 Ia ALKALI METALS	GROUP 2 IIa ALKALINE EARTH METALS	GROUP 3 IIIa	GROUP 4 IVa	GROUP 5 Va	GROUP 6 VIa	GROUP 7 VIIa	GROUP 8 VIIIa TRIADS	GROUP 9	GROUP 10	GROUP 11 Ib	GROUP 12 IIb	GROUP 13 IIIa EARTH METALS	GROUP 14 IVa CARBON GROUP	GROUP 15 Va NITROGEN GROUP	GROUP 16 VIa OXYGEN GROUP	GROUP 17 VIIa HALOGENS	GROUP 18 0 NOBLE GASES
PERIOD 1	<div style="display: flex; justify-content: space-between;"> <div style="width: 15%;"> <p>1 1.008 Hydrogen <b>H</b> 1.0 +I 1s<sup>1</sup></p> </div> <div style="width: 15%; text-align: right;"> <p>2 4.003 Helium <b>He</b> -- 0 1s<sup>2</sup></p> </div> </div>																	
PERIOD 2	<div style="display: flex; justify-content: space-between;"> <div style="width: 15%;"> <p>3 6.94 Lithium <b>Li</b> 1.0 +I 1s<sup>2</sup>2s<sup>1</sup></p> </div> <div style="width: 15%; text-align: right;"> <p>4 9.012 Beryllium <b>Be</b> 1.6 +II 1s<sup>2</sup>2s<sup>2</sup></p> </div> </div>																	
PERIOD 3	<div style="display: flex; justify-content: space-between;"> <div style="width: 15%;"> <p>11 22.99 Sodium <b>Na</b> 0.9 +I [Ne] 3s<sup>1</sup></p> </div> <div style="width: 15%; text-align: right;"> <p>12 24.31 Magnesium <b>Mg</b> 1.2 +II [Ne] 3s<sup>2</sup></p> </div> </div>																	
PERIOD 4	<div style="display: flex; justify-content: space-between;"> <div style="width: 15%;"> <p>19 39.10 Potassium <b>K</b> 0.8 +I [Ar] 4s<sup>1</sup></p> </div> <div style="width: 15%; text-align: right;"> <p>20 40.08 Calcium <b>Ca</b> 1.0 +II [Ar] 4s<sup>2</sup></p> </div> </div>																	
PERIOD 5	<div style="display: flex; justify-content: space-between;"> <div style="width: 15%;"> <p>37 85.47 Rubidium <b>Rb</b> 0.8 +I [Kr] 5s<sup>1</sup></p> </div> <div style="width: 15%; text-align: right;"> <p>38 87.62 Strontium <b>Sr</b> 1.0 +II [Kr] 5s<sup>2</sup></p> </div> </div>																	
PERIOD 6	<div style="display: flex; justify-content: space-between;"> <div style="width: 15%;"> <p>55 132.91 Cesium <b>Cs</b> 0.7 +I [Xe] 6s<sup>1</sup></p> </div> <div style="width: 15%; text-align: right;"> <p>56 137.33 Barium <b>Ba</b> 1.0 +II [Xe] 6s<sup>2</sup></p> </div> </div>																	
PERIOD 7	<div style="display: flex; justify-content: space-between;"> <div style="width: 15%;"> <p>87 (223) Francium <b>Fr</b> 0.7 +I [Rn] 7s<sup>1</sup></p> </div> <div style="width: 15%; text-align: right;"> <p>88 (226) Radium <b>Ra</b> 0.9 +II [Rn] 7s<sup>2</sup></p> </div> </div>																	
PERIOD 8	<div style="display: flex; justify-content: space-between;"> <div style="width: 15%;"> <p>58 140.12 Cerium <b>Ce</b> 1.1 +III +IV [Xe] 4f<sup>1</sup>5d<sup>1</sup>6s<sup>2</sup></p> </div> <div style="width: 15%; text-align: right;"> <p>59 140.91 Praseodymium <b>Pr</b> 1.1 +III [Xe] 4f<sup>3</sup>6s<sup>2</sup></p> </div> </div>																	
PERIOD 9	<div style="display: flex; justify-content: space-between;"> <div style="width: 15%;"> <p>90 232.04 Thorium <b>Th</b> [Rn] 6d<sup>2</sup>7s<sup>2</sup></p> </div> <div style="width: 15%; text-align: right;"> <p>91 231.04 Protactinium <b>Pa</b> [Rn] 5f<sup>2</sup>6d<sup>2</sup>7s<sup>2</sup></p> </div> </div>																	
PERIOD 10	<div style="display: flex; justify-content: space-between;"> <div style="width: 15%;"> <p>60 144.24 Neodymium <b>Nd</b> 1.1 +III [Xe] 4f<sup>4</sup>6s<sup>2</sup></p> </div> <div style="width: 15%; text-align: right;"> <p>61 (145) Promethium <b>Pm</b> [Xe] 4f<sup>5</sup>6s<sup>2</sup></p> </div> </div>																	
PERIOD 11	<div style="display: flex; justify-content: space-between;"> <div style="width: 15%;"> <p>62 150.36 Samarium <b>Sm</b> 1.2 +III +IV [Xe] 4f<sup>6</sup>6s<sup>2</sup></p> </div> <div style="width: 15%; text-align: right;"> <p>63 151.96 Europium <b>Eu</b> 1.2 +III +IV [Xe] 4f<sup>7</sup>6s<sup>2</sup></p> </div> </div>																	
PERIOD 12	<div style="display: flex; justify-content: space-between;"> <div style="width: 15%;"> <p>64 157.25 Gadolinium <b>Gd</b> 1.2 +III [Xe] 4f<sup>7</sup>5d<sup>1</sup>6s<sup>2</sup></p> </div> <div style="width: 15%; text-align: right;"> <p>65 158.93 Terbium <b>Tb</b> 1.2 +III [Xe] 4f<sup>9</sup>6s<sup>2</sup></p> </div> </div>																	
PERIOD 13	<div style="display: flex; justify-content: space-between;"> <div style="width: 15%;"> <p>66 162.50 Dysprosium <b>Dy</b> 1.2 +III [Xe] 4f<sup>10</sup>6s<sup>2</sup></p> </div> <div style="width: 15%; text-align: right;"> <p>67 164.93 Holmium <b>Ho</b> 1.2 +III [Xe] 4f<sup>11</sup>6s<sup>2</sup></p> </div> </div>																	
PERIOD 14	<div style="display: flex; justify-content: space-between;"> <div style="width: 15%;"> <p>68 167.26 Erbium <b>Er</b> 1.2 +III [Xe] 4f<sup>12</sup>6s<sup>2</sup></p> </div> <div style="width: 15%; text-align: right;"> <p>69 168.93 Thulium <b>Tm</b> 1.3 +III [Xe] 4f<sup>13</sup>6s<sup>2</sup></p> </div> </div>																	
PERIOD 15	<div style="display: flex; justify-content: space-between;"> <div style="width: 15%;"> <p>70 173.05 Ytterbium <b>Yb</b> 1.1 +III +IV [Xe] 4f<sup>14</sup>6s<sup>2</sup></p> </div> <div style="width: 15%; text-align: right;"> <p>71 174.97 Lutetium <b>Lu</b> 1.3 +III [Xe] 4f<sup>14</sup>5d<sup>1</sup>6s<sup>2</sup></p> </div> </div>																	

This practical Periodic Table of the Elements (PTE, Mendeleev table) has been carefully compiled using the most recent atomic data.

It is primarily intended for educational use in secondary and higher education.

All essential information on the 118 chemical elements is included in this table, while unnecessary data (such as melting and boiling points or electrons per shell) have been omitted.

This PTE includes the following practical data for each element:

- its chemical symbol
- its name
- its atomic number Z
- its relative atomic weight A<sub>r</sub>
- its electronegativity value
- its possible oxidation states
- its electron configuration
- the type of element
- its state of matter at room temperature

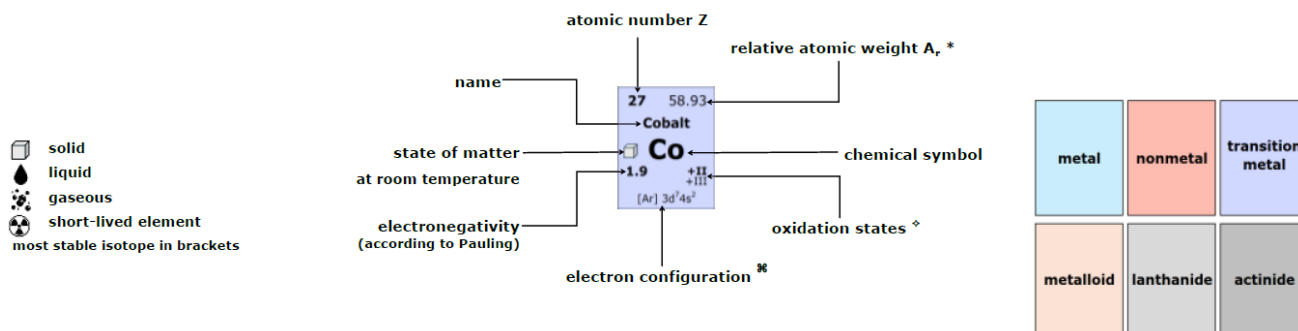

The **atomic number (Z)** is displayed in bold in the upper left corner.

The **relative atomic weight ( $A_r$ )** is shown next to it in regular font. These data were published in 2022 by the International Union of Pure and Applied Chemistry (IUPAC). For practical calculations of molecular masses, atomic masses are displayed with two decimal places or four significant figures.

For elements whose isotopes are all short-lived (radioisotopes only), the atomic mass is shown in parentheses. For thorium, protactinium, and uranium, which each have one more stable isotope, an atomic mass is provided along with the symbol for short-lived elements (☢).

Below, the **name of the element** is shown in smaller font, while its **chemical symbol** is displayed prominently.

The **state of matter** of the pure element at room temperature (solid, liquid, gas, or short-lived element) is indicated by a symbol located to the left of the element symbol.

On the next line, the **electronegativity** according to Pauling is shown on the left, rounded to one decimal place.

Next to this, the **oxidation states** are listed. The most important valencies in compounds are shown in bold, while other valencies are displayed in regular font.

The abbreviated **electron configuration** according to Bohr–Sommerfeld is shown at the bottom.

The color of each box immediately indicates the **type of element**, i.e. metal, non-metal, metalloid, transition metal, lanthanide, actinide, or noble gas.

# Backside

The reverse side of this PTE contains useful constants related to chemical equilibrium. These data are presented in a clear tabular format. The data have been thoroughly verified and are derived from reference works such as: *CRC Handbook of Chemistry and Physics | Fundamentals of Analytical Chemistry (2021)*, *Skoog, West, Holler & Crouch | Book of Data, Revised Nuffield Advanced Science (1984)*

ACID / BASE EQUILIBRIUM <i>pK<sub>a</sub></i> = constant base		
HCl	Cl <sup>-</sup>	-7.1
HBr	Br <sup>-</sup>	-9
HI	I <sup>-</sup>	-10
H <sub>2</sub> SO <sub>4</sub>	HSO <sub>4</sub> <sup>-</sup>	1000
H <sub>2</sub> SO <sub>3</sub>	HSO <sub>3</sub> <sup>-</sup>	1000
HNO <sub>2</sub>	NO <sub>2</sub> <sup>-</sup>	200
HCO <sub>2</sub> H	HCO <sub>2</sub> <sup>-</sup>	3.75
H <sub>2</sub> CO <sub>3</sub>	HCO <sub>3</sub> <sup>-</sup>	6.3
H <sub>2</sub> CO <sub>3</sub>	CO <sub>3</sub> <sup>2-</sup>	10.3
HNO <sub>3</sub>	NO <sub>3</sub> <sup>-</sup>	25
HClO <sub>4</sub>	ClO <sub>4</sub> <sup>-</sup>	10
H <sub>2</sub> O	OH <sup>-</sup>	14
Cl <sub>2</sub> C=COOH	Cl <sub>2</sub> C=COO <sup>-</sup>	2.0 E-1
H <sub>2</sub> C=COOH	H <sub>2</sub> C=COO <sup>-</sup>	1.8 E-1
H <sub>2</sub> O	IO <sub>3</sub> <sup>-</sup>	1.7 E-1
H <sub>2</sub> O	H <sub>2</sub> P <sub>2</sub> O <sub>7</sub> <sup>2-</sup>	1.2 E-1
H <sub>2</sub> O	NH <sub>4</sub> <sup>+</sup>	9.2 E-2
H <sub>2</sub> O	H <sub>2</sub> P <sub>2</sub> O <sub>7</sub> <sup>2-</sup>	7.9 E-2
COOH	HCOO <sup>-</sup>	3.75
H <sub>2</sub> O	H <sub>2</sub> P <sub>2</sub> O <sub>7</sub> <sup>2-</sup>	5.0 E-2
Cl <sub>2</sub> HC=COOH	Cl <sub>2</sub> HC=COO <sup>-</sup>	4.5 E-2
H <sub>2</sub> O	IO <sub>4</sub> <sup>-</sup>	2.3 E-2
H <sub>2</sub> O	HSO <sub>4</sub> <sup>-</sup>	1.4 E-2
H <sub>2</sub> O	ClO <sub>2</sub> <sup>-</sup>	1.2 E-2
H <sub>2</sub> O	HSO <sub>3</sub> <sup>-</sup>	1.0 E-2
H <sub>2</sub> O	H <sub>2</sub> P <sub>2</sub> O <sub>7</sub> <sup>2-</sup>	7.9 E-3
H <sub>2</sub> O	H <sub>2</sub> P <sub>2</sub> O <sub>7</sub> <sup>2-</sup>	6.9 E-3
Fe(OH) <sub>3</sub>	Fe(OH) <sub>2</sub>	6.3 E-2
H <sub>2</sub> SO <sub>4</sub>	H <sub>2</sub> SO <sub>4</sub>	5.5 E-3
H <sub>2</sub> SO <sub>3</sub>	H <sub>2</sub> SO <sub>3</sub>	1.6 E-4
H <sub>2</sub> SO <sub>4</sub>	HSO <sub>4</sub> <sup>-</sup>	2.5 E-3
H <sub>2</sub> SO <sub>3</sub>	HSO <sub>3</sub> <sup>-</sup>	1.4 E-3
H <sub>2</sub> SO <sub>4</sub>	HSO <sub>4</sub> <sup>-</sup>	1.0 E-2
H <sub>2</sub> SO <sub>3</sub>	HSO <sub>3</sub> <sup>-</sup>	7.9 E-3
H <sub>2</sub> SO <sub>4</sub>	H <sub>2</sub> SO <sub>4</sub>	6.3 E-3
Fe(OH) <sub>3</sub>	Fe(OH) <sub>2</sub>	6.3 E-2
H <sub>2</sub> SO <sub>4</sub>	H <sub>2</sub> SO <sub>4</sub>	5.5 E-3
H <sub>2</sub> SO <sub>3</sub>	H <sub>2</sub> SO <sub>3</sub>	1.6 E-4
H <sub>2</sub> SO <sub>4</sub>	HSO <sub>4</sub> <sup>-</sup>	2.5 E-3
H <sub>2</sub> SO <sub>3</sub>	HSO <sub>3</sub> <sup>-</sup>	1.4 E-3
H <sub>2</sub> SO <sub>4</sub>	HSO <sub>4</sub> <sup>-</sup>	1.0 E-2
H <sub>2</sub> SO <sub>3</sub>	HSO <sub>3</sub> <sup>-</sup>	7.9 E-3
H <sub>2</sub> SO <sub>4</sub>	H <sub>2</sub> SO <sub>4</sub>	6.3 E-3
Fe(OH) <sub>3</sub>	Fe(OH) <sub>2</sub>	6.3 E-2
H <sub>2</sub> SO <sub>4</sub>	H <sub>2</sub> SO <sub>4</sub>	5.5 E-3
H <sub>2</sub> SO <sub>3</sub>	H <sub>2</sub> SO <sub>3</sub>	1.6 E-4
H <sub>2</sub> SO <sub>4</sub>	HSO <sub>4</sub> <sup>-</sup>	2.5 E-3
H <sub>2</sub> SO <sub>3</sub>	HSO <sub>3</sub> <sup>-</sup>	1.4 E-3
H <sub>2</sub> SO <sub>4</sub>	HSO <sub>4</sub> <sup>-</sup>	1.0 E-2
H <sub>2</sub> SO <sub>3</sub>	HSO <sub>3</sub> <sup>-</sup>	7.9 E-3
H <sub>2</sub> SO <sub>4</sub>	H <sub>2</sub> SO <sub>4</sub>	6.3 E-3
Fe(OH) <sub>3</sub>	Fe(OH) <sub>2</sub>	6.3 E-2
H <sub>2</sub> SO <sub>4</sub>	H <sub>2</sub> SO <sub>4</sub>	5.5 E-3
H <sub>2</sub> SO <sub>3</sub>	H <sub>2</sub> SO <sub>3</sub>	1.6 E-4
H <sub>2</sub> SO <sub>4</sub>	HSO <sub>4</sub> <sup>-</sup>	2.5 E-3
H <sub>2</sub> SO <sub>3</sub>	HSO <sub>3</sub> <sup>-</sup>	1.4 E-3
H <sub>2</sub> SO <sub>4</sub>	HSO <sub>4</sub> <sup>-</sup>	1.0 E-2
H <sub>2</sub> SO <sub>3</sub>	HSO <sub>3</sub> <sup>-</sup>	7.9 E-3
H <sub>2</sub> SO <sub>4</sub>	H <sub>2</sub> SO <sub>4</sub>	6.3 E-3
Fe(OH) <sub>3</sub>	Fe(OH) <sub>2</sub>	6.3 E-2
H <sub>2</sub> SO <sub>4</sub>	H <sub>2</sub> SO <sub>4</sub>	5.5 E-3
H <sub>2</sub> SO <sub>3</sub>	H <sub>2</sub> SO <sub>3</sub>	1.6 E-4
H <sub>2</sub> SO <sub>4</sub>	HSO <sub>4</sub> <sup>-</sup>	2.5 E-3
H <sub>2</sub> SO <sub>3</sub>	HSO <sub>3</sub> <sup>-</sup>	1.4 E-3
H <sub>2</sub> SO <sub>4</sub>	HSO <sub>4</sub> <sup>-</sup>	1.0 E-2
H <sub>2</sub> SO <sub>3</sub>	HSO <sub>3</sub> <sup>-</sup>	7.9 E-3
H <sub>2</sub> SO <sub>4</sub>	H <sub>2</sub> SO <sub>4</sub>	6.3 E-3
Fe(OH) <sub>3</sub>	Fe(OH) <sub>2</sub>	6.3 E-2
H <sub>2</sub> SO <sub>4</sub>	H <sub>2</sub> SO <sub>4</sub>	5.5 E-3
H <sub>2</sub> SO <sub>3</sub>	H <sub>2</sub> SO <sub>3</sub>	1.6 E-4
H <sub>2</sub> SO <sub>4</sub>	HSO <sub>4</sub> <sup>-</sup>	2.5 E-3
H <sub>2</sub> SO <sub>3</sub>	HSO <sub>3</sub> <sup>-</sup>	1.4 E-3
H <sub>2</sub> SO <sub>4</sub>	HSO <sub>4</sub> <sup>-</sup>	1.0 E-2
H <sub>2</sub> SO <sub>3</sub>	HSO <sub>3</sub> <sup>-</sup>	7.9 E-3
H <sub>2</sub> SO <sub>4</sub>	H <sub>2</sub> SO <sub>4</sub>	6.3 E-3
Fe(OH) <sub>3</sub>	Fe(OH) <sub>2</sub>	6.3 E-2
H <sub>2</sub> SO <sub>4</sub>	H <sub>2</sub> SO <sub>4</sub>	5.5 E-3
H <sub>2</sub> SO <sub>3</sub>	H <sub>2</sub> SO <sub>3</sub>	1.6 E-4
H <sub>2</sub> SO <sub>4</sub>	HSO <sub>4</sub> <sup>-</sup>	2.5 E-3
H <sub>2</sub> SO <sub>3</sub>	HSO <sub>3</sub> <sup>-</sup>	1.4 E-3
H <sub>2</sub> SO <sub>4</sub>	HSO <sub>4</sub> <sup>-</sup>	1.0 E-2
H <sub>2</sub> SO <sub>3</sub>	HSO <sub>3</sub> <sup>-</sup>	7.9 E-3
H <sub>2</sub> SO <sub>4</sub>	H <sub>2</sub> SO <sub>4</sub>	6.3 E-3
Fe(OH) <sub>3</sub>	Fe(OH) <sub>2</sub>	6.3 E-2
H <sub>2</sub> SO <sub>4</sub>	H <sub>2</sub> SO <sub>4</sub>	5.5 E-3
H <sub>2</sub> SO <sub>3</sub>	H <sub>2</sub> SO <sub>3</sub>	1.6 E-4
H <sub>2</sub> SO <sub>4</sub>	HSO <sub>4</sub> <sup>-</sup>	2.5 E-3
H <sub>2</sub> SO <sub>3</sub>	HSO <sub>3</sub> <sup>-</sup>	1.4 E-3
H <sub>2</sub> SO <sub>4</sub>	HSO <sub>4</sub> <sup>-</sup>	1.0 E-2
H <sub>2</sub> SO <sub>3</sub>	HSO <sub>3</sub> <sup>-</sup>	7.9 E-3
H <sub>2</sub> SO <sub>4</sub>	H <sub>2</sub> SO <sub>4</sub>	6.3 E-3
Fe(OH) <sub>3</sub>	Fe(OH) <sub>2</sub>	6.3 E-2
H <sub>2</sub> SO <sub>4</sub>	H <sub>2</sub> SO <sub>4</sub>	5.5 E-3
H <sub>2</sub> SO <sub>3</sub>	H <sub>2</sub> SO <sub>3</sub>	1.6 E-4
H <sub>2</sub> SO <sub>4</sub>	HSO <sub>4</sub> <sup>-</sup>	2.5 E-3
H <sub>2</sub> SO <sub>3</sub>	HSO <sub>3</sub> <sup>-</sup>	1.4 E-3
H <sub>2</sub> SO <sub>4</sub>	HSO <sub>4</sub> <sup>-</sup>	1.0 E-2
H <sub>2</sub> SO <sub>3</sub>	HSO <sub>3</sub> <sup>-</sup>	7.9 E-3
H <sub>2</sub> SO <sub>4</sub>	H <sub>2</sub> SO <sub>4</sub>	6.3 E-3
Fe(OH) <sub>3</sub>	Fe(OH) <sub>2</sub>	6.3 E-2
H <sub>2</sub> SO <sub>4</sub>	H <sub>2</sub> SO <sub>4</sub>	5.5 E-3
H <sub>2</sub> SO <sub>3</sub>	H <sub>2</sub> SO <sub>3</sub>	1.6 E-4
H <sub>2</sub> SO <sub>4</sub>	HSO <sub>4</sub> <sup>-</sup>	2.5 E-3
H <sub>2</sub> SO <sub>3</sub>	HSO <sub>3</sub> <sup>-</sup>	1.4 E-3
H <sub>2</sub> SO <sub>4</sub>	HSO <sub>4</sub> <sup>-</sup>	1.0 E-2
H <sub>2</sub> SO <sub>3</sub>	HSO <sub>3</sub> <sup>-</sup>	7.9 E-3
H <sub>2</sub> SO <sub>4</sub>	H <sub>2</sub> SO <sub>4</sub>	6.3 E-3
Fe(OH) <sub>3</sub>	Fe(OH) <sub>2</sub>	6.3 E-2
H <sub>2</sub> SO <sub>4</sub>	H <sub>2</sub> SO <sub>4</sub>	5.5 E-3
H <sub>2</sub> SO <sub>3</sub>	H <sub>2</sub> SO <sub>3</sub>	1.6 E-4
H <sub>2</sub> SO <sub>4</sub>	HSO <sub>4</sub> <sup>-</sup>	2.5 E-3
H <sub>2</sub> SO <sub>3</sub>	HSO <sub>3</sub> <sup>-</sup>	1.4 E-3
H <sub>2</sub> SO <sub>4</sub>	HSO <sub>4</sub> <sup>-</sup>	1.0 E-2
H <sub>2</sub> SO <sub>3</sub>	HSO <sub>3</sub> <sup>-</sup>	7.9 E-3
H <sub>2</sub> SO <sub>4</sub>	H <sub>2</sub> SO <sub>4</sub>	6.3 E-3
Fe(OH) <sub>3</sub>	Fe(OH) <sub>2</sub>	6.3 E-2
H <sub>2</sub> SO <sub>4</sub>	H <sub>2</sub> SO <sub>4</sub>	5.5 E-3
H <sub>2</sub> SO <sub>3</sub>	H <sub>2</sub> SO <sub>3</sub>	1.6 E-4
H <sub>2</sub> SO <sub>4</sub>	HSO <sub>4</sub> <sup>-</sup>	2.5 E-3
H <sub>2</sub> SO <sub>3</sub>	HSO <sub>3</sub> <sup>-</sup>	1.4 E-3
H <sub>2</sub> SO <sub>4</sub>	HSO <sub>4</sub> <sup>-</sup>	1.0 E-2
H <sub>2</sub> SO <sub>3</sub>	HSO <sub>3</sub> <sup>-</sup>	7.9 E-3
H <sub>2</sub> SO <sub>4</sub>	H <sub>2</sub> SO <sub>4</sub>	6.3 E-3
Fe(OH) <sub>3</sub>	Fe(OH) <sub>2</sub>	6.3 E-2
H <sub>2</sub> SO <sub>4</sub>	H <sub>2</sub> SO <sub>4</sub>	5.5 E-3
H <sub>2</sub> SO <sub>3</sub>	H <sub>2</sub> SO <sub>3</sub>	1.6 E-4
H <sub>2</sub> SO <sub>4</sub>	HSO <sub>4</sub> <sup>-</sup>	2.5 E-3
H <sub>2</sub> SO <sub>3</sub>	HSO <sub>3</sub> <sup>-</sup>	1.4 E-3
H <sub>2</sub> SO <sub>4</sub>	HSO <sub>4</sub> <sup>-</sup>	1.0 E-2
H <sub>2</sub> SO <sub>3</sub>	HSO <sub>3</sub> <sup>-</sup>	7.9 E-3
H <sub>2</sub> SO <sub>4</sub>	H <sub>2</sub> SO <sub>4</sub>	6.3 E-3
Fe(OH) <sub>3</sub>	Fe(OH) <sub>2</sub>	6.3 E-2
H <sub>2</sub> SO <sub>4</sub>	H <sub>2</sub> SO <sub>4</sub>	5.5 E-3
H <sub>2</sub> SO <sub>3</sub>	H <sub>2</sub> SO <sub>3</sub>	1.6 E-4
H <sub>2</sub> SO <sub>4</sub>	HSO <sub>4</sub> <sup>-</sup>	2.5 E-3
H <sub>2</sub> SO <sub>3</sub>	HSO <sub>3</sub> <sup>-</sup>	1.4 E-3
H <sub>2</sub> SO <sub>4</sub>	HSO <sub>4</sub> <sup>-</sup>	1.0 E-2
H <sub>2</sub> SO <sub>3</sub>	HSO <sub>3</sub> <sup>-</sup>	7.9 E-3
H <sub>2</sub> SO <sub>4</sub>	H <sub>2</sub> SO <sub>4</sub>	6.3 E-3
Fe(OH) <sub>3</sub>	Fe(OH) <sub>2</sub>	6.3 E-2
H <sub>2</sub> SO <sub>4</sub>	H <sub>2</sub> SO <sub>4</sub>	5.5 E-3
H <sub>2</sub> SO <sub>3</sub>	H <sub>2</sub> SO <sub>3</sub>	1.6 E-4
H <sub>2</sub> SO <sub>4</sub>	HSO <sub>4</sub> <sup>-</sup>	2.5 E-3
H <sub>2</sub> SO <sub>3</sub>	HSO <sub>3</sub> <sup>-</sup>	1.4 E-3
H <sub>2</sub> SO <sub>4</sub>	HSO <sub>4</sub> <sup>-</sup>	1.0 E-2
H <sub>2</sub> SO <sub>3</sub>	HSO <sub>3</sub> <sup>-</sup>	7.9 E-3
H <sub>2</sub> SO <sub>4</sub>	H <sub>2</sub> SO <sub>4</sub>	6.3 E-3
Fe(OH) <sub>3</sub>	Fe(OH) <sub>2</sub>	6.3 E-2
H <sub>2</sub> SO <sub>4</sub>	H <sub>2</sub> SO <sub>4</sub>	5.5 E-3
H <sub>2</sub> SO <sub>3</sub>	H <sub>2</sub> SO <sub>3</sub>	1.6 E-4
H <sub>2</sub> SO <sub>4</sub>	HSO <sub>4</sub> <sup>-</sup>	2.5 E-3
H <sub>2</sub> SO <sub>3</sub>	HSO <sub>3</sub> <sup>-</sup>	1.4 E-3
H <sub>2</sub> SO <sub>4</sub>	HSO <sub>4</sub> <sup>-</sup>	1.0 E-2
H <sub>2</sub> SO <sub>3</sub>	HSO <sub>3</sub> <sup>-</sup>	7.9 E-3
H <sub>2</sub> SO <sub>4</sub>	H <sub>2</sub> SO <sub>4</sub>	6.3 E-3
Fe(OH) <sub>3</sub>	Fe(OH) <sub>2</sub>	6.3 E-2
H <sub>2</sub> SO <sub>4</sub>	H <sub>2</sub> SO <sub>4</sub>	5.5 E-3
H <sub>2</sub> SO <sub>3</sub>	H <sub>2</sub> SO <sub>3</sub>	1.6 E-4
H <sub>2</sub> SO <sub>4</sub>	HSO <sub>4</sub> <sup>-</sup>	2.5 E-3
H <sub>2</sub> SO <sub>3</sub>	HSO <sub>3</sub> <sup>-</sup>	1.4 E-3
H <sub>2</sub> SO <sub>4</sub>	HSO <sub>4</sub> <sup>-</sup>	1.0 E-2
H <sub>2</sub> SO <sub>3</sub>	HSO <sub>3</sub> <sup>-</sup>	7.9 E-3
H <sub>2</sub> SO <sub>4</sub>	H <sub>2</sub> SO <sub>4</sub>	6.3 E-3
Fe(OH) <sub>3</sub>	Fe(OH) <sub>2</sub>	6.3 E-2
H <sub>2</sub> SO <sub>4</sub>	H <sub>2</sub> SO <sub>4</sub>	5.5 E-3
H <sub>2</sub> SO <sub>3</sub>	H <sub>2</sub> SO <sub>3</sub>	1.6 E-4
H <sub>2</sub> SO <sub>4</sub>	HSO <sub>4</sub> <sup>-</sup>	2.5 E-3
H <sub>2</sub> SO <sub>3</sub>	HSO <sub>3</sub> <sup>-</sup>	1.4 E-3
H <sub>2</sub> SO <sub>4</sub>	HSO <sub>4</sub> <sup>-</sup>	1.0 E-2
H <sub>2</sub> SO <sub>3</sub>	HSO <sub>3</sub> <sup>-</sup>	7.9 E-3
H <sub>2</sub> SO <sub>4</sub>	H <sub>2</sub> SO <sub>4</sub>	6.3 E-3
Fe(OH) <sub>3</sub>	Fe(OH) <sub>2</sub>	6.3 E-2
H <sub>2</sub> SO <sub>4</sub>	H <sub>2</sub> SO <sub>4</sub>	5.5 E-3
H <sub>2</sub> SO <sub>3</sub>	H <sub>2</sub> SO <sub>3</sub>	1.6 E-4
H <sub>2</sub> SO <sub>4</sub>	HSO <sub>4</sub> <sup>-</sup>	2.5 E-3
H <sub>2</sub> SO <sub>3</sub>	HSO <sub>3</sub> <sup>-</sup>	1.4 E-3
H <sub>2</sub> SO <sub>4</sub>	HSO <sub>4</sub> <sup>-</sup>	1.0 E-2
H <sub>2</sub> SO <sub>3</sub>	HSO <sub>3</sub> <sup>-</sup>	7.9 E-3
H <sub>2</sub> SO <sub>4</sub>	H <sub>2</sub> SO <sub>4</sub>	6.3 E-3
Fe(OH) <sub>3</sub>	Fe(OH) <sub>2</sub>	6.3 E-2
H <sub>2</sub> SO <sub>4</sub>	H <sub>2</sub> SO <sub>4</sub>	5.5 E-3
H <sub>2</sub> SO <sub>3</sub>	H <sub>2</sub> SO <sub>3</sub>	1.6 E-4
H <sub>2</sub> SO <sub>4</sub>	HSO <sub>4</sub> <sup>-</sup>	2.5 E-3
H <sub>2</sub> SO <sub>3</sub>	HSO <sub>3</sub> <sup>-</sup>	1.4 E-3
H <sub>2</sub> SO <sub>4</sub>	HSO <sub>4</sub> <sup>-</sup>	1.0 E-2
H <sub>2</sub> SO <sub>3</sub>	HSO <sub>3</sub> <sup>-</sup>	7.9 E-3
H <sub>2</sub> SO <sub>4</sub>	H <sub>2</sub> SO <sub>4</sub>	6.3 E-3
Fe(OH) <sub>3</sub>	Fe(OH) <sub>2</sub>	6.3 E-2
H <sub>2</sub> SO <sub>4</sub>	H <sub>2</sub> SO <sub>4</sub>	5.5 E-3
H <sub>2</sub> SO <sub>3</sub>	H <sub>2</sub> SO <sub>3</sub>	1.6 E-4
H <sub>2</sub> SO <sub>4</sub>	HSO <sub>4</sub> <sup>-</sup>	2.5 E-3
H <sub>2</sub> SO <sub>3</sub>	HSO <sub>3</sub> <sup>-</sup>	1.4 E-3
H <sub>2</sub> SO <sub>4</sub>	HSO <sub>4</sub> <sup>-</sup>	1.0 E-2
H <sub>2</sub> SO <sub>3</sub>	HSO <sub>3</sub> <sup>-</sup>	7.9 E-3
H <sub>2</sub> SO <sub>4</sub>	H <sub>2</sub> SO <sub>4</sub>	6.3 E-3
Fe(OH) <sub>3</sub>	Fe(OH) <sub>2</sub>	6.3 E-2
H <sub>2</sub> SO <sub>4</sub>	H <sub>2</sub> SO <sub>4</sub>	5.5 E-3
H <sub>2</sub> SO <sub>3</sub>	H <sub>2</sub> SO <sub>3</sub>	1.6 E-4
H <sub>2</sub> SO <sub>4</sub>	HSO <sub>4</sub> <sup>-</sup>	2.5 E-3
H <sub>2</sub> SO <sub>3</sub>	HSO <sub>3</sub> <sup>-</sup>	1.4 E-3
H <sub>2</sub> SO <sub>4</sub>	HSO <sub>4</sub> <sup>-</sup>	1.0 E-2
H <sub>2</sub> SO <sub>3</sub>	HSO <sub>3</sub> <sup>-</sup>	7.9 E-3
H <sub>2</sub> SO <sub>4</sub>	H <sub>2</sub> SO <sub>4</sub>	6.3 E-3
Fe(OH) <sub>3</sub>	Fe(OH) <sub>2</sub>	6.3 E-2
H <sub>2</sub> SO <sub>4</sub>	H <sub>2</sub> SO <sub>4</sub>	5.5 E-3
H <sub>2</sub> SO <sub>3</sub>	H <sub>2</sub> SO <sub>3</sub>	1.6 E-4
H <sub>2</sub> SO <sub>4</sub>	HSO <sub>4</sub> <sup>-</sup>	2.5 E-3
H <sub>2</sub> SO <sub>3</sub>	HSO <sub>3</sub> <sup>-</sup>	1.4 E-3
H <sub>2</sub> SO <sub>4</sub>	HSO <sub>4</sub> <sup>-</sup>	1.0 E-2
H <sub>2</sub> SO <sub>3</sub>	HSO <sub>3</sub> <sup>-</sup>	7.9 E-3
H <sub>2</sub> SO <sub>4</sub>	H <sub>2</sub> SO <sub>4</sub>	6.3 E-3
Fe(OH) <sub>3</sub>	Fe(OH) <sub>2</sub>	6.3 E-2
H <sub>2</sub> SO <sub>4</sub>	H <sub>2</sub> SO <sub>4</sub>	5.5 E-3
H <sub>2</sub> SO <sub>3</sub>	H <sub>2</sub> SO <sub>3</sub>	1.6 E-4
H <sub>2</sub> SO <sub>4</sub>	HSO <sub>4</sub> <sup>-</sup>	2.5 E-3
H <sub>2</sub> SO <sub>3</sub>	HSO <sub>3</sub> <sup>-</sup>	1.4 E-3
H <sub>2</sub> SO <sub>4</sub>	HSO <sub>4</sub> <sup>-</sup>	1.0 E-2
H <sub>2</sub> SO <sub>3</sub>	HSO <sub>3</sub> <sup>-</sup>	7.9 E-3
H <sub>2</sub> SO <sub>4</sub>	H <sub>2</sub> SO <sub>4</sub>	6.3 E-3
Fe(OH) <sub>3</sub>	Fe(OH) <sub>2</sub>	6.3 E-2
H <sub>2</sub> SO <sub>4</sub>	H <sub>2</sub> SO <sub>4</sub>	5.5 E-3
H <sub>2</sub> SO <sub>3</sub>	H <sub>2</sub> SO <sub>3</sub>	1.6 E-4
H <sub>2</sub> SO <sub>4</sub>	HSO <sub>4</sub> <sup>-</sup>	2.5 E-3
H <sub>2</sub> SO <sub>3</sub>	HSO <sub>3</sub> <sup>-</sup>	1.4 E-3
H <sub>2</sub> SO <sub>4</sub>	HSO <sub>4</sub> <sup>-</sup>	1.0 E-2
H <sub>2</sub> SO <sub>3</sub>	HSO <sub>3</sub> <sup>-</sup>	7.9 E-3
H <sub>2</sub> SO <sub>4</sub>	H <sub>2</sub> SO <sub>4</sub>	6.3 E-3
Fe(OH) <sub>3</sub>	Fe(OH) <sub>2</sub>	6.3 E-2
H <sub>2</sub> SO <sub>4</sub>	H <sub>2</sub> SO <sub>4</sub>	5.5 E-3
H <sub>2</sub> SO <sub>3</sub>	H <sub>2</sub> SO <sub>3</sub>	1.6 E-4
H <sub>2</sub> SO <sub>4</sub>	HSO <sub>4</sub> <sup>-</sup>	2.5 E-3
H <sub>2</sub> SO <sub>3</sub>	HSO <sub>3</sub> <sup>-</sup>	1.4 E-3
H <sub>2</sub> SO <sub>4</sub>	HSO <sub>4</sub> <sup>-</sup>	1.0 E-2
H <sub>2</sub> SO <sub>3</sub>	HSO <sub>3</sub> <sup>-</sup>	7.9 E-3
H <sub>2</sub> SO <sub>4</sub>	H <sub>2</sub> SO <sub>4</sub>	6.3 E-3

## Why using this PTE?

As a chemistry teacher and tutor, I have found that many periodic tables used in education do not always align with the theory taught in chemistry classes. This can be confusing for pupils and students and often leads to misconceptions. Therefore, this periodic table was designed with didactic principles in mind, as well as practical experience with common student misconceptions.

For **acid dissociation constants**, both  $K_a$  and  $pK_a$  values are included (as the data should also be usable without prior knowledge of logarithmic functions). The  $K_a$  values were calculated and rounded based on literature values of  $pK_a$ .

**Solubility products** indicate how difficult it is for a precipitate to dissolve and represent the heterogeneous equilibrium between an insoluble salt and its dissolved ions.

**Formation constants of complexes** indicate how easily a complex is formed. Complexes are generally very stable, and their formation (or stability) constants are typically high. Instead, some periodic tables show the inverse dissociation constants.

In electrochemistry, the **standard reduction potential** (or standard electrode potential) is used. This is the value in volts associated with a reduction half-reaction. Therefore, in this PTE, all half-reactions are presented as reductions. In some periodic tables half-reactions are shown as oxidations while still listing the corresponding reduction potential.

## Terms of use

This periodic table was designed by Cobalt Blue Coaching and is protected by copyright. Free use is permitted for private and educational purposes. Commercial use is not allowed without permission.

© 2024 Cobalt blue coaching CC BY-NC 4.0



**Private use:** The document may be downloaded free of charge and used for personal purposes.

**Educational use:** Educational institutions may freely use the document for teaching purposes. Printing and distribution to pupils or students is permitted.

**Commercial use:** Copying or distributing the document for commercial purposes, in any form, is not permitted.

## Comments or Further information

Although this PTE has been compiled with great care, minor errors may still occur. Reporting any errors is greatly appreciated. After verification, corrections will be made and an updated version will be published on the website.

A printer-friendly version is also available.

Any suggestions to improve this PTE are greatly appreciated.

+32 470 61 23 07 or  
[info@cobaltbluecoaching.be](mailto:info@cobaltbluecoaching.be)

## Voluntary contribution

This document is offered free of charge for private and educational use. Schools or users who wish to support this project are welcome to make a voluntary contribution. These contributions help keep the material up to date and freely available on the website.

Many schools choose to contribute € 10 to € 30 when using the material in their lessons. Any contribution is appreciated; suggested amounts are:

- € 10 for a small school
- € 20 for a medium-sized school
- € 30 for a larger school or

Voluntary contributions can be made to: IBAN: **BE65 0018 7776 4796**

Thank you for using this PTE and for your support!

*Kim De Wael*

